

Thinking of you Christchurch

The team at Autoline Automation send their sincerest condolences to those affected by the earthquake and the wider Christchurch community. It has been a tragic and difficult month for you and your families. We have watched this tragedy bring out the best in humanity with real acts of sacrifice, courage and kindness. We encourage you to remain strong as your lives, properties and businesses are rebuilt.

INSIDE THIS ISSUE



AluPro Elevator Conveyor	2
Machine Guarding	2
Bowl Feeding Tip	3
Eriez Metal Detectors	3
Turnkey Automation & Design Solutions	4

New Product line Etipack Labelling Solutions



Autoline has further expanded its range of automation solutions with the Etipack range of high quality label application, printing and dispensing equipment.

Etipack has been a leading designer of labelling and coding systems for self adhesive labels, feeders and pick & place devices since 1978. The company has a precise mission: optimising technological resources in order to create flexible solutions tailored to user requirements, by means of modular machinery that can be personalised according to the specific needs of particular industrial sectors.

Etipack labellers are designed to satisfy four objectives: high-performance, flexibility, reliability and ease of maintenance. Available in a variety of different standard configurations with an array of optional accessories, like print units, applicators according product shapes, support structures, barcode readers the four models, Clear, Surprise, Original and Super, satisfy a wide range of requirements from small businesses to large industries and for both standard and customized applications.

Contact us today for a no obligation quotation and assesment of your application requirements.



Turnkey
Automation
& Design
solutions
Page 4





Autoline Automation's Gratis Guard modular safety system provides security and strength to protect you or your staff during machinery operations. The Gratis Guard modular safety system is fully customisable, using MayTec Slot Profiles that can be cut to suit, the guards can be taken apart and reassembled using many options to suit virtually any situation. Our Industrial safety fencing range is an excellent choice and we will help you design machine guards to the AS4024.1 Standard.



Department of Labour focusing on inadequate Machine guards in Industry

The Department of Labour is urging manufacturers to ensure their machinery is properly guarded and machines are being used safely. Too many people are dying, or being seriously injured at work because machines are not properly guarded, according to the Department of Labour.

"Each year hundreds of workers are seriously hurt because machinery with inadequate guarding is being used," says Dr Geraint Emrys, the Department's Chief Adviser Health and Safety.

"On top of that there have been five deaths in the past five years where workers have paid the ultimate price for the failure of employers to properly guard machinery."

The Department is so concerned at the prevalence of fatal and serious harm injuries in this area that it has a national project underway to raise awareness of proper machine guarding.

"Our inspectors have been focusing on the common mechanical hazards across all machinery for which there are well-known and established standards for machine guarding," Dr Emrys added.

"Dangerous machinery must be properly guarded or positioned out of the reach of employees. Effective procedures that cover operating, cleaning and maintaining equipment must be in place and staff must be trained to use the machines safely." While staff need to stop and think before they work on a machine, no worker should be put in the position where a bad decision can kill them, or crush or amputate limbs. For more information on the Department of Labour's machine guarding focus visit www.dol.govt.nz

Contact us about Gratis Guard Modular safety systems and how we can help you ensure your machinery is adequately guarded.

AluPro Elevator Conveyor - New Addition

We have added an elevator conveyor to our popular AluPro conveyor range.

These are an extremely compact unit with an internal 3ph drive for the head pulley. Typical applications are removal of small parts from injection moulding machines and elevating product from a Vertical form fill seal machine.

We can provide a customized solution for your unique application. Side walls, cleats, or flat belts are all available. Contact us for all your conveying requirements as due to their modular construction AluPro conveyors are very cost effective.



MayTec For Machine Bases

Many manufacturers of special purpose machinery are switching over from fabricated machine frames to more flexible solutions using extruded aluminium profiles. We offer a comprehensive range of aluminium profiles and accessories which can be used in various applications including machine guarding, work & assembly stations and, of course, machine frames. For the special purpose machine manufacturer, choosing the right product & supplier for the machine frame can

be as important as delivering the finished manufacturing solution to the end customer on time and to spec. Very often the benefit of such a flexible solution can make a difference of weeks to the delivery, even with each profile system having its own characteristics or perhaps by having a "standard" machine base which can be adapted further down the machine design process.

Autoline offers a free system design service and are able to deliver a large range of profiles from stock.



The MayTec system is the strongest and cost effective modular systems available, talk to us today for your next machine building project.

Eriez Industrial Metal Detectors

Eriez Magnetics is a World leader in Magnetic separation for the Food, Metal & Heavy Industrial Industries. As part of their range Eriez offer Industrial metal detectors particularly suited to quarry and mining operations for detection of tramp metals as part of a protection system for downstream processing equipment. The detection system operates by measuring the change in received electromagnetic



signal of material being conveyed through the sensor area. Since the magnetic properties of a material are completely independent of conductivity, both magnetic and nonmagnetic tramp metals are consistently detected.

Benefits

- Excellent sensitivity even at high belt speeds
- Highly resilient to electrical noise interference
- Detector can operate with variable belt speeds
- Able to detect metal even on steel corded belts (Hawk Model)
- Able to operate with highly conductive products e.g. iron ore (Hawk model)
- Compact design for easy installation
- Supplied as a flat pack and simple to assemble
- No need to cut the conveyor belt to install

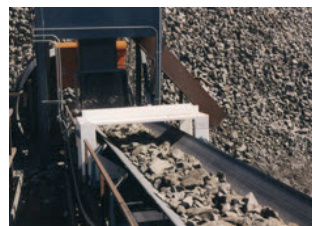

Clear labeller

Clear is a compact labeller with speeds of up to 20 metres/minute designed for low to medium speed packaging lines or end-offline applications. It has the technology and structure of an industrial labeller: Clear is solid, accurate and reliable. Please contact us for more information to enable us to specify to you application.

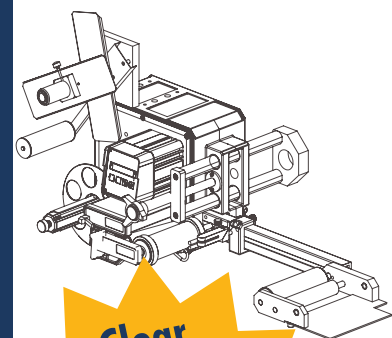

**Clear
Solid
Accurate
Reliable**

Website Launch

2011 has seen the launch of our new website at www.autolineautomation.co.nz. You are able to keep up to date with industry news and access key information about how our product ranges could assist your business. There is a wealth of information and full product catalogues available for download. Bookmark it now and keep an eye out for the automation industry's latest developments with Autoline Automation.



Internal drive drums

Our Range of internal drive drums are a reliable solution for drive motors when constructing conveyors or replacing failed drives. Available in 72, 82, 112mm dia. Download our catalogue from our website:

www.autolineautomation.co.nz

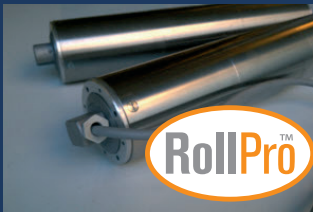

Autoline Automation Ltd
 8 Stuart Street, Blenheim 7201
 PO Box 45-017, Blenheim 7240
 Free Phone: 0800 37 55 66
 Free Fax: 0800 37 55 99
 E: sales@autolineautomation.co.nz
 Web: www.autolineautomation.co.nz

Turn-key Automation and Design Solutions

Autoline Automation has formed an alliance with Axis Professional Ltd, a company specialising in process flow optimisation, product design, fire safety design and drafting services. With this exciting partnership we are now able to offer you a more complete and comprehensive solution to your automation and process requirements.

We are also able to provide full turnkey solutions for your automation requirements. From a conveyor complete with label applicator, to fully automated custom built product handling systems, we can provide the solutions. For more information on this exciting new venture contact us or the team at Axis on www.axisgroup.co.nz

Recent projects we have undertaken include:

- Batch weighing systems
- Linear vibrator feeding
- Product rotation, cooling and handling
- Bowl feeding and tooling
- Conveyor Systems
- Machine Guarding design

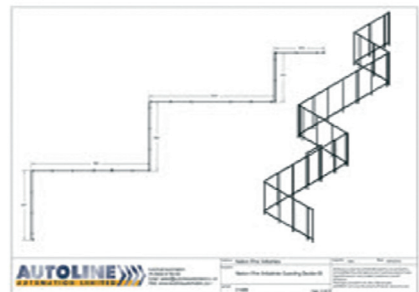
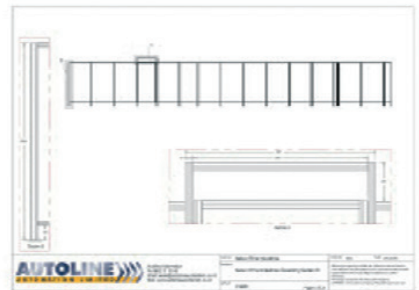
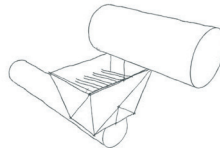
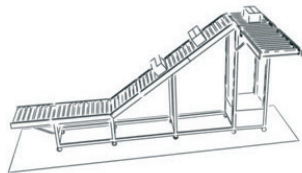
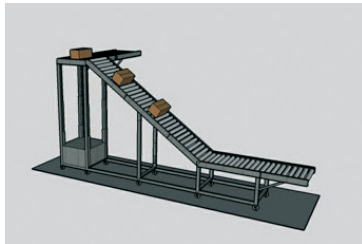

Email: sales@autolineautomation.co.nz
 Web: www.autolineautomation.co.nz
 Freephone: 0800 37 55 66